

COMMERCIAL LAUNDRY SYSTEMS

LAUNDRY LOUNGE

Better living through enjoyable laundry service.



TECHNICAL SPECIFICATIONS

TITAN-C

TITAN-C Washer



| | | Non-Heater FH0C7FD*L/TCWL2013*** | Heater FH0C7FD3S |
|--|-----------|--|------------------------------------|
| CYLINDER | | | |
| Drum Volume | cu.ft (ℓ) | 5.2 (147) | 5.2 (147) |
| Diameter | in. (mm) | 24 (610.8) | 24 (610.8) |
| Depth | in. (mm) | 20.4 (518.1) | 20.4 (518.1) |
| DIMENSIONS | | | |
| Product (WxHxD) | in | 29 x 40.8 x 32 | 29 x 40.8 x 32 |
| | mm | 737 x 1,036 x 814 | 737 x 1,036 x 814 |
| With Door Open | in. (mm) | 53 (1,370) | 53 (1,370) |
| | in | 31 x 44.3 x 33.3 | 31 x 44.3 x 33.3 |
| Carton (WxHxD) | mm | 788 x 1,125 x 846 | 788 x 1,125 x 846 |
| | lb (kg) | 221.8 (100.6) / 248 (112.5) | 221.8 (100.6) / 248 (112.5) |
| SPEED | | | |
| Wash | RPM | 46 | 46 |
| Extract (Max RPM) | RPM | 1000 | 980 |
| G-force | G | 340 | 327 |
| RATING | | | |
| Electric Ratings | V/Hz/A | 120/60/5 | 220-240/50/14-17 |
| | | 220-240/50/5 | |
| | | 220/60/5 | |
| *CONSUMPTION INDEX¹⁾ | | | |
| Water | gal (l) | 16.5 (62.5) | 12.4(47) |
| Electricity | kWh/cycle | 0.077 | 3.2-3.8 |
| NOISE & CYCLE TIME | | | |
| Noise Level (Sound Power) | dB | Lower than 62 | Lower than 62 |
| Program Duration in Minutes (Default) | min | 36 | 59 |
| SYSTEM & CONTROL | | | |
| Inverter Direct Drive Motor | | O | O |
| Heating Element | W | 120V 1,000 (Only for Tub Clean) 220V 2,000 (Only for Tub Clean) | 3,200 |
| Drain System | | BLDC | Gravity Drain |
| Emergency Stop Button | | O (OPL Only) | O (OPL Only) |
| Inlet Valve | | DC | AC |
| Auto Dosing Interface | | O | O |
| Gyro Sensor | | O | X |
| Damper | | 4 Friction Dampers | 4 Friction Dampers |
| PROGRAMS | | | |
| Program List | | Hot* | 90°C |
| | | Warm* | 75°C |
| | | Cold* | 60°C |
| | | Delicates* | 40°C/30°C |
| | | Add Super Wash (Card & Coin)/ 20 Custom PGM (OPL) | Cold * Custom PGM ²⁾ |
| EXTERNAL FINISH | | | |
| Drum | | Stainless Steel | Stainless Steel |
| CIRCUIT PROTECTION | | | |
| PCB Fuse - Main Control Board | amps | 12 (220-240V) | 12 (220-240V) |
| PCB Fuse- Filter Assembly | amps | 15 | 15 |
| Main PCB MICOM | | T470 | T370 |

*Dimensions and weights are approximate. *Design, features, and specifications subject to change without notice.
 *Some models may not be available for sale in certain countries. *Model name may vary by country
 *Energy Course available
 1) Based on DOE J2/J1 testing
 2) When you press button for 3 seconds, Cold cycle will be changed to Custom PGM. (Cold for coin model, Custom PGM for OPL model)

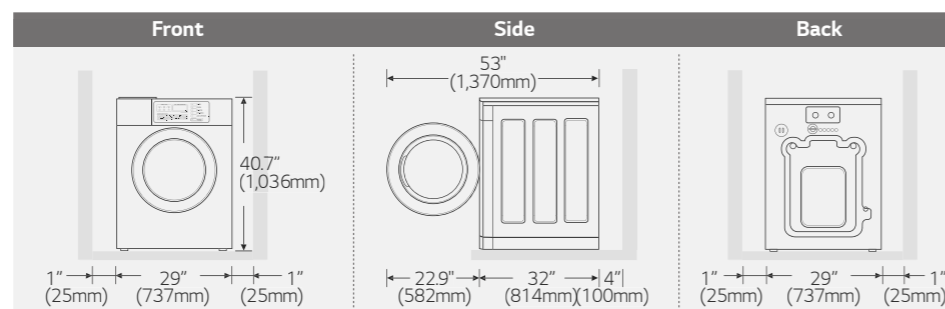

TITAN-C Dryer



| | | Gas RN1870A** / TCD1870*** |
|-----------------------------|-----------|---|
| CYLINDER | | |
| Drum Volume | cu.ft (ℓ) | 9.0 (254) |
| Diameter | in. (mm) | 28.2 (716) |
| Depth | in. (mm) | 24.2 (614) |
| DIMENSIONS | | |
| Product (WxHxD) | in | 29 x 40.2 x 42.9 |
| | mm | 737 x 1,022 x 1,090 |
| With Door Open | in. (mm) | 65.1 (1,655) |
| | in | Single : 30.7 x 44.7 x 44.4 Stack : 30.7 x 83.1 x 44.4 |
| Carton (WxHxD) | mm | Single : 781 x 1,137 x 1,128 Stack : 781 x 2,110 x 1,128 |
| | lb (kg) | 220 (100)/240 (108.8) |
| RATING | | |
| Electric Ratings | V/Hz/A | 120/60/10 |
| SYSTEM & CONTROL | | |
| Heating Type | | Gas (Default LNG) |
| Type of Drying | W | Ventilation |
| Air Flow | CFM | 350 |
| Drum Motor | kW | 0.5 (120V/60Hz) |
| Fan Motor | kW | 0.3 |
| Gas Ratings | BTU/hour | 55,000 |
| CONNECTIONS | | |
| Air Outlet Diameter | in. (mm) | 6 (154) |
| Exhaust Airflow Diameter | in. (mm) | 6 (154) |
| PROGRAMS | | |
| Program List | | High Temp |
| | | Med Temp |
| | | Low Temp |
| | | No Heat |
| EXTERNAL FINISH | | |
| Drum | | Stainless Steel |

* Dimensions and weights are approximate. * Design, features and specifications subject to change without notice.
 * Some models may not be available for sale in certain countries. * Model name may vary by country.

