

SHOP DRAWING FOR LAUNDRY

MOBILE WORK TABLE WITH 2 U/S

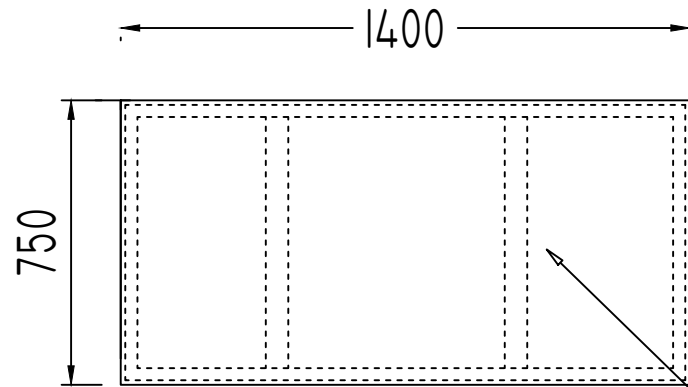

PLAN

16 SWG. S.S. 304 SHEET TOP
FRONT TURNED DN. 50MM IN
12MM

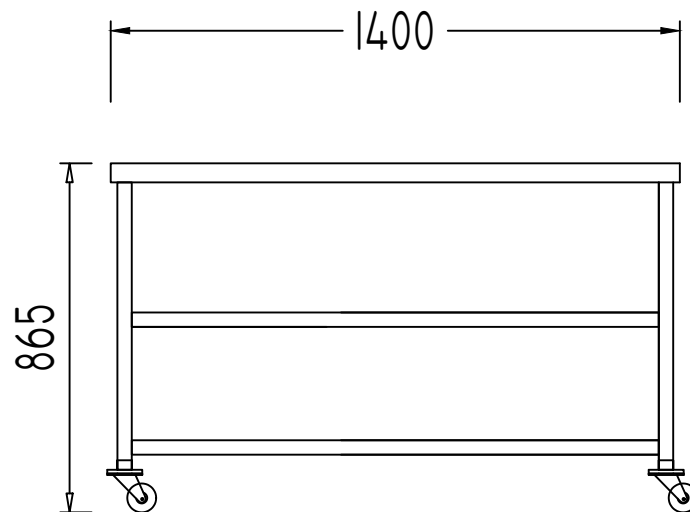

ELEVATION

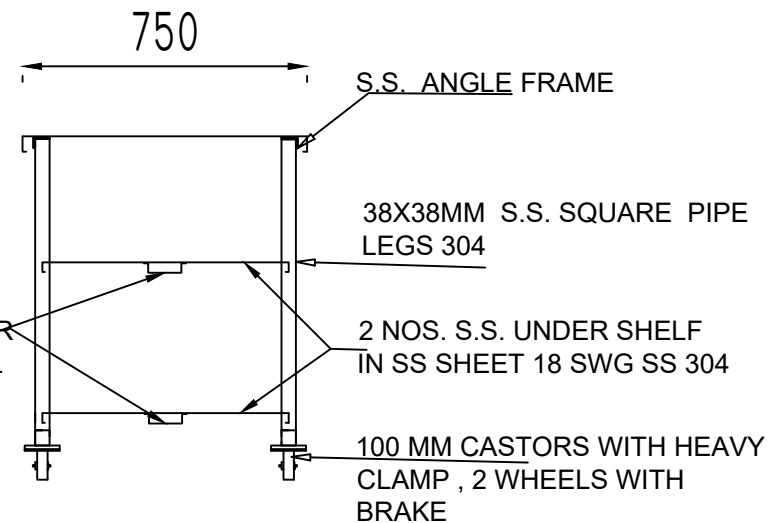

SECTION

ITEM NO - L-26, SIZE L1400XW750XH865 QTY. 06 .